

Parts Information:  
**Air Palm Orbital Sander Ø150mm Dust-Free**  
**Model No: SA09**

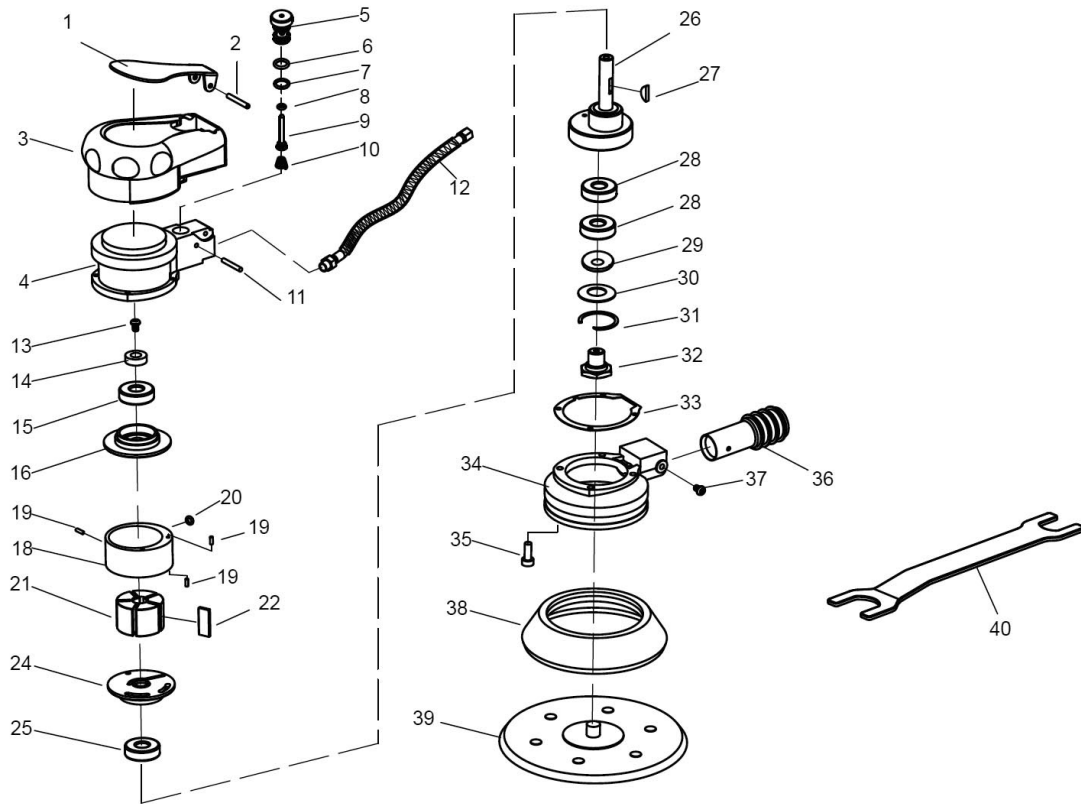

Item	Part No.	Description
1	SA09.01	VALVE LEVER
2	SA09.02	SPRING PIN
3	SA09.03	BODY COVER
4	SA09.04	BODY
5	SA09.05	VALVE PIN SLEEVE
6	SA09.06	O-RING
7	SA09.07	O-RING
8	SA09.08	O-RING
9	SA09.09	VALVE
10	SA09.10	VALVE SPRING
11	SA09.11	NEEDLE PIN
12	SA09.12	AIR INTAKE PIPE
13	SA09.13	PAN HEAD MACHINE SCREW M5X8
14	SA09.14	SPACER
15	B/6000ZZ	BEARING 6000ZZ
16	SA09.16	REAR PLATE
17	SA09.17	REAR DISC
18	SA09.18	CYLINDER
19	SA09.19	SPRING PIN
20	SA09.20	O-RING

Item	Part No.	Description
21	SA09.21	ROTOR
22	SA09.22	ROTOR BLADE (SET OF 5)
24	SA09.24	FRONT PLATE
25	B/6000ZZ	BEARING 6000ZZ
26	SA09.26	ROTOR SHAFT
27	SA09.27	KEY
28	B/6001-2RS	BEARING 6001-2RS
29	SA09.29	FELT WASHER
30	SA09.30	DUST SEAL
31	SA09.31	SNAP RING
32	SA09.32	PAD RETAINER
33	SA09.33	GASKET
34	SA09.34	BASE RING
35	SCB512.SB	SOCKET HEAD CAP SCREW M5x12 BLACK
36	SA09.36	AIR INTAKE HOSE
37	MSP48.S	MACHINE SCREW PAN HEAD PHILLIPS M4x8mm
38	SA09.38	HOOD
39	PTC150DFV	DUST-FREE BACKING PAD HOOK & LOOP 145mm
40	SA09.40	SPANNER

**NOTE:** It is our policy to continually improve products and as such we reserve the right to alter data, specifications and component parts without prior notice.

**IMPORTANT:** No liability is accepted for incorrect use of product.

**WARRANTY:** Guarantee is 12 months from purchase date, proof of which will be required for any claim.