



Instructions For: **AIR OPERATED
PANEL DRYER
SDA01**
Model:

Thank you for purchasing a Sealey product. Manufactured to a high standard this product will, if used according to these instructions and properly maintained, give you years of trouble free performance.

IMPORTANT: PLEASE READ THESE INSTRUCTIONS CAREFULLY. NOTE THE SAFE OPERATIONAL REQUIREMENTS, WARNINGS AND CAUTIONS. USE THE PRODUCT CORRECTLY AND WITH CARE FOR THE PURPOSE FOR WHICH IT IS INTENDED. FAILURE TO DO SO MAY CAUSE DAMAGE AND/OR PERSONAL INJURY, AND WILL INVALIDATE THE WARRANTY. PLEASE KEEP INSTRUCTIONS SAFE FOR FUTURE USE.

1. SAFETY INSTRUCTIONS

- ✓ Familiarise yourself with this products application and limitations.
- ❑ **WARNING!** Disconnect the dryer from the air supply before performing any maintenance.
- ✓ Maintain the dryer in good condition (use an authorised service agent).
- ✓ Replace or repair damaged parts. *Use recommended parts only. Unauthorised parts may be dangerous and will invalidate the warranty.*
- ✓ Locate the dryer in an adequate working area for its function, keep area clean and tidy and free from unrelated materials, and ensure there is adequate ventilation and lighting.
- ✓ Keep the dryer clean for best and safest performance.
- ✓ Ensure the air system is suitable to the dryer consumption, (see specifications).
- ✓ Keep children and unauthorised persons away from the working area.
- ✓ When not in use ensure the air supply is turned off.
- x DO NOT use the dryer for any purpose other than for which it is designed.
- x DO NOT operate dryer if any parts are missing or damaged as this may cause failure or personal injury.
- x DO NOT direct air from the air hose at yourself or others.
- ✓ When not in use switch the dryer off, and disconnect from the air supply.



2. INTRODUCTION AND SPECIFICATION

Designed for drying water-based paints. Panel dryer operates on workshop air supply. Filter prevents airborne particles contaminating paint surface. Ideal for localized or spot repair. May be hand-held or mounted on optional Double Support Stand Model No. SDAST

Max Working Pressure: 90psi
 Air Consumption:10cfm @ 15psi, 18cfm @ 90psi
 Air Connection1/4" BSP

3. AIR SUPPLY CONNECTION

3.1. Air Supply

Recommended hook-up procedure is shown in (Fig. 1).

3.1.1. Ensure dryer air valve is in the 'OFF' position before connecting to the air supply.

3.1.2. You will require air pressure and air flow according to specification.

❑ **WARNING!** Ensure the air supply is clean and does not exceed 90 psi while operating the dryer. Too high an air pressure and unclean air will shorten the product life due to excessive wear, and may be dangerous causing damage and/or personal injury.

3.1.3. Drain the air tank daily. Water in the air line will damage the dryer.

3.1.4. Clean air inlet filter weekly.

3.1.5. Keep hoses away from heat, oil and sharp edges. Check hoses for wear, and make certain that all connections are secure.

3.2. Couplings.

Movement can cause failure if a quick change coupling is connected directly to the dryer when used without optional stand, Model No. SDAST. To overcome this, connect a leader hose to the dryer. A quick change coupling may then be used to connect the leader hose to the air line recoil hose (See Fig. 1 & 2).

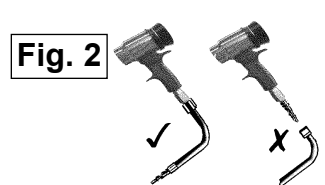
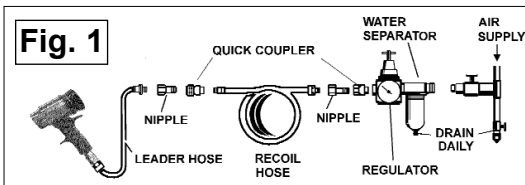

4. OPERATION

- 4.1 Connect dryer to air supply as described in section 3.
- 4.2 Ensure the valve is in the 'OFF' (Fig. 3) position and turn on the air supply.
- 4.3 Open the valve (Fig. 3) to proceed, you can regulate the air flow by the amount you open the valve.
- 4.4 The SDA01 may either be used as a handheld device or used in conjunction with SDAST Double Stand (Fig. 4) enabling the user to leave the dryer(s) operating unattended.
- 4.5 When finished, turn off, disconnect from the air supply and store in a dry location.

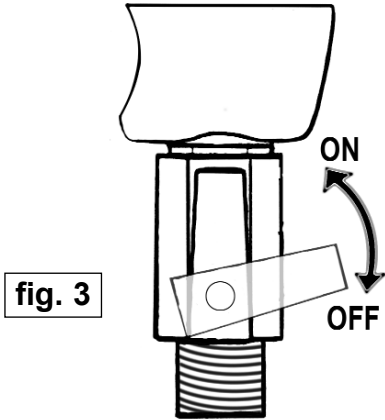

5. PARTS

Issue: 1
Date: 011206

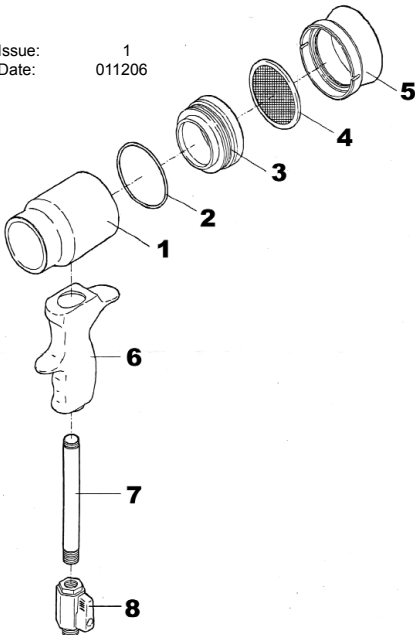

ITEM	PART No.	DESCRIPTION
1	SDA01.01	AIR NOZZLE HOUSING
2	SDA01.02	O-RING
3	SDA01.03	INTAKE HOUSING
4	SDA01.04	FILTER
5	SDA01.05	FILTER HOLDER
6	SDA01.06	HANDLE
7	SDA01.07	AIR FEED TUBE
8	SDA01.08	ON/OFF VALVE

NOTE: It is our policy to continually improve products and as such we reserve the right to alter data, specifications and component parts without prior notice. **IMPORTANT:** No liability is accepted for incorrect use of product. **WARRANTY:** Guarantee is 12 months from purchase date, proof of which will be required for any claim. **INFORMATION:** For a copy of our latest catalogue and promotions call us on 01284 757525 and leave your full name and address, including postcode.



Sole UK Distributor
Sealey Group,
Bury St. Edmunds, Suffolk.

01284 757500
01284 703534



www.sealey.co.uk
sales@sealey.co.uk