



INSTRUCTIONS FOR: SPACE WARMER PARAFFIN / KEROSENE / DIESEL HEATERS

MODEL NO: **AB708.V2**

Thank you for purchasing a Sealey product. Manufactured to a high standard, this product will, if used according to these instructions and maintained properly, give you years of trouble free performance.

IMPORTANT: PLEASE READ THESE INSTRUCTIONS CAREFULLY. NOTE THE SAFE OPERATIONAL REQUIREMENTS, WARNINGS & CAUTIONS. USE THE PRODUCT CORRECTLY AND WITH CARE FOR THE PURPOSE FOR WHICH IT IS INTENDED. FAILURE TO DO SO MAY CAUSE DAMAGE AND/OR PERSONAL INJURY AND WILL INVALIDATE THE WARRANTY. KEEP THESE INSTRUCTIONS SAFE FOR FUTURE USE.



Refer to instruction
manual



Warning: automatic
start-up



Warning: hot
surface

1. SAFETY

1.1. ELECTRICAL SAFETY

WARNING! It is the responsibility of the owner and the operator to read, understand and comply with the following:

You must check all electrical products, before use, to ensure that they are safe. You must inspect power cables, plugs, sockets and any other connectors for wear or damage. You must ensure that the risk of electric shock is minimised by the installation of appropriate safety devices. A Residual Current Circuit Breaker (RCCB) should be incorporated in the main distribution board. We also recommend that a Residual Current Device (RCD) is used. It is particularly important to use an RCD with portable products that are plugged into a supply which is not protected by an RCCB. If in any doubt consult a qualified electrician. You may obtain a Residual Current Device by contacting your Sealey dealer.

You must also read and understand the following instructions concerning electrical safety.

1.1.1. The **Electricity at Work Act 1989** requires all portable electrical appliances, if used on business premises, to be tested by a qualified electrician, using a Portable Appliance Tester (PAT), at least once a year.

1.1.2. The **Health & Safety at Work Act 1974** makes owners of electrical appliances responsible for the safe condition of those appliances and the safety of the appliance operators. **If in any doubt about electrical safety, contact a qualified electrician.**

1.1.3. Ensure that the insulation on all cables and on the appliance is safe before connecting it to the power supply. See 1.1.1. and 1.1.2. and use a Portable Appliance Tester.

1.1.4. Ensure that cables are always protected against short circuit and overload.

1.1.5. Regularly inspect power supply cables and plugs for wear or damage and check all connections to ensure that none are loose.

1.1.6. **Important:** Ensure that the voltage marked on the appliance matches the power supply to be used and that the plug is fitted with the correct fuse - see fuse rating at right.

1.1.7. **DO NOT** pull or carry the appliance by the power cable.

1.1.8. **DO NOT** pull the plug from the socket by the cable.

1.1.9. **DO NOT** use worn or damaged cables, plugs or connectors. Immediately have any faulty item repaired or replaced by a qualified electrician. When an ASTA/BS approved UK 3 pin plug is damaged, cut the cable just above the plug and **dispose of the plug safely.** Fit a new plug according to the following instructions (UK only).

a) Connect the **GREEN/YELLOW earth wire to the earth terminal 'E'.**

b) Connect the **BROWN live wire to the live terminal 'L'.**

c) Connect the **BLUE neutral wire to the neutral terminal 'N'.**

d) **After wiring, check that there are no bare wires, that all wires have been correctly connected, that the cable outer insulation extends beyond the cable restraint and that the restraint is tight.**

1.1.10. If an extension reel is used it should be fully unwound before connection. A reel with an RCD fitted is preferred since any appliance plugged into it will be protected. The cable core section is important and should be at least 1.5mm², but to be absolutely sure that the capacity of the reel is suitable for this product and for others which may be used in the other output sockets, we recommend the use of 2.5mm² section cable.

1.2. GENERAL SAFETY

▲ DANGER! Risk of carbon monoxide poisoning. Failure to provide proper ventilation could result in serious illness or death.

✓ Check that the heater is in sound condition and good working order. *Take immediate action to repair or replace damaged parts.*

✓ Use recommended parts only. *Unapproved parts may be dangerous and will invalidate the warranty.*

✓ Only use clean paraffin, kerosene or diesel (**NOT BIO-DIESEL**) to fuel your heater, in accordance with instructions contained in this manual

WARNING! Only use heater in well ventilated areas. Ensure continuous ventilation from outside of the building is provided to the heater operating area. Allow at least 3ft² opening/100000Btu/hr output.

✓ Keep the front of the heater a minimum of 2.4 metres and the rear and sides 1.2 metres from any combustible materials (i.e. wooden items, cloth, plastics, paper, tarpaulins or similar enclosure materials).

✓ Only operate on a level and stable surface.

WARNING! DO NOT use the heater near flammable material, liquids, solids, gases or compressed gas cylinders.

DO NOT use the heater in closed rooms, living areas, basements or below ground level.

DO NOT allow untrained persons to operate the heater and **DO NOT** operate the heater without the cover.

DO NOT move or handle the heater when hot.

DO NOT leave the heater unattended when in use. Switch the heater off and unplug from the mains before leaving work area.

DO NOT fill the fuel tank whilst the heater is running or still hot.

DO NOT overfill the fuel container. Wipe up any spilled fuel immediately.

DO NOT obstruct the air inlet (rear) and air outlet (front) of the heater. **DO NOT** use duct work in front or at the rear of the heater.

DO NOT look into the exhaust end of the heater.

DO NOT allow children or animals near the heater when in use, or while hot.

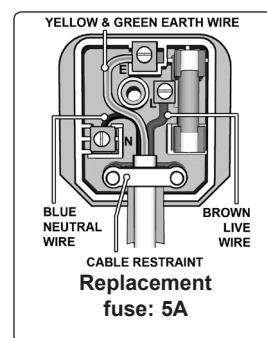

- ❑ **WARNING! RISK OF ELECTRIC SHOCK. DO NOT** expose the heater to water spray, rain, dripping water or wind.
- ✗ **DO NOT** operate the heater when you are tired or under the influence of alcohol, drugs or intoxicating medication.
- ✗ **DO NOT** touch the heater outlet or dome when first switched off as these are very hot and will take time to cool.
- ✓ Ensure that the heater is correctly turned off when not in use and store in a safe, dry area, out of reach of children.
- ✗ **DO NOT** unplug the heater to switch it off. Use the ON/OFF switch.

❑ **WARNING!** Improper maintenance can lead to poor combustion and soot production

NOTE: This appliance is not intended for persons (including children) with reduced physical, sensory or mental capabilities, or lack of experience and knowledge, unless they have been given supervision or instruction concerning use of the appliance by a person responsible for their safety. Children should be supervised to ensure that they do not play with the appliance.

2. INTRODUCTION

Our range of Paraffin/Kerosene/Diesel Heaters represents excellent value. Workshop tried and tested. The range includes two economy portable units, Model No's AB458 and AB708, which are both supplied without wheels. All except Model No. AB458 have an adjustable thermostat (°C). Model No. AB1008 and above are fitted with digital room temperature (°C) display/error code readout and spare parts storage compartment. Proven pump systems handle either paraffin, kerosene or diesel with only minor adjustment of air compressor. All models are fitted with fuel tank gauge and heavy-duty fuel cap. Model No's AB1008, AB1258, AB1758 and AB2158 feature cable storage on handle. Model No. AB7081 and above are supplied with heavy-duty wheels.

3. SPECIFICATION

Model No:	AB708.V2
Output:	20.5kW
Output:	70,000Btu/hr
Tank Capacity:	19ltr
Fuel:	Paraffin/Kerosene/Diesel
Supply:	230V - 5A
Running Time per Filling (Maximum):	9hr
Airflow:	240cfm
Automatic Shut-Off:	Yes
Heated Area:	13,600ft ³
Heated Area:	385mtr ³
Weight:	12.7kg

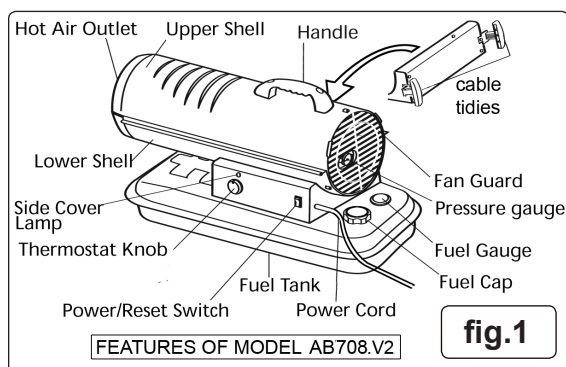

- ❑ **WARNING! This heater is not suitable for use with Bio-Diesel; use of Bio-Diesel will damage the filter and seals. Damage caused by use of Bio-Diesel will not be covered by warranty.**

4. ASSEMBLY

4.1. FITTING TOP HANDLE

Align the holes in the handle with the holes in the upper housing. Insert and tighten the screws provided with a cross headed screwdriver as shown in fig.3.

4.2. ASSEMBLING THE CABLE TIDIES

Mount the cable ties onto either end of the panel on the other side of the heater from the main control panel, as shown in fig.1. Hook the two tabs on each moulding into the holes at either end of the panel. The tongue on each moulding should now be lying on the face of the panel. Secure each moulding in place with a screw through the tongue and into the ready made holes in the panel.

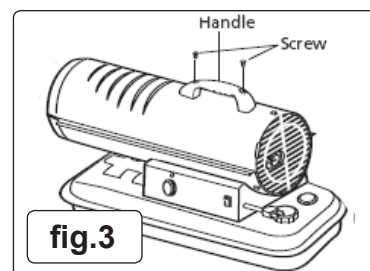

5. PREPARATION

5.1. PARAFFIN, KEROSENE AND DIESEL FUEL USAGE

These AB heaters are factory adjusted to give the most efficient burn on paraffin and kerosene but will also burn diesel. Note that paraffin and kerosene will tend to burn more cleanly than diesel. Care should be taken to provide at least the minimum amount of ventilation recommended when burning diesel.

- ❑ **WARNING! Never use any other fuel such as petrol, benzene, alcohol, camping stove fuel, paint thinners or other oil compounds. USE OF THESE VOLATILE FUELS MAY CAUSE A FIRE OR EXPLOSION.**

5.2. STORAGE OF FUEL

Always store paraffin, kerosene and diesel in a well ventilated area well away from general living space. **DO NOT** store in direct sunlight or near a source of heat or other source of ignition such as a torch or a portable generator. **DO NOT** use fuel that has been stored from one season to the next as it may have deteriorated and will not burn properly in the heater. Store the fuel in a suitable container which complies with requirements set out in local authority regulations.

5.3. FILLING THE FUEL TANK

Never fill the fuel tank indoors. Always fill the fuel tank outdoors on a level surface. Take note of the position of the fuel gauge whilst filling the tank and **DO NOT** overfill it. **Never refill the tank whilst the heater is operating or is still hot.**

5.5 SITING THE HEATER

Always install the heater so that it will not be directly exposed to water spray, rain, dripping water or wind. The heater should not be placed near to any combustible materials. The minimum clearance from combustibles is **1.2m** from the top of the heater, **1.2m** from the sides of the heater and **2.4m** from the front of the heater. Never use the heater in spaces which contain products such as petrol, solvents, paint thinners, dust particles, volatile or airborne combustibles, or any unknown chemicals.

- ❑ **WARNING! Air contaminants taken into the heater may affect the heat output, damage the unit and may cause health problems. Example: Bodyshop filler dust / paint overspray will damage the motor bearing, clog the filter and pump and contaminate the combustion chamber causing flame flutter and health hazards. Please note that any parts damaged by filler dust / paint overspray will not be covered by warranty. Additionally, a cleaning charge will be made for any heaters damaged by filler dust.**

6.1. OPERATING SYSTEM

- 6.1.1 **FUEL SYSTEM.** The heater is equipped with an air pump that operates off the electric motor. The pump forces air through the air line connected to the fuel tank, drawing fuel to the nozzle in the burning head. Air also passes through the nozzle where it mixes with the fuel and is sprayed into the combustion chamber in a fine mist.
- 6.1.2. **QUICK FIRE IGNITION.** A transformer sends high voltage to a two pronged spark plug. The resultant spark ignites the fuel air mixture as it is sprayed into the combustion chamber.
- 6.1.3. **AIR SYSTEM.** A fan is turned by the heavy duty motor which forces air around and into the combustion chamber, where it is super heated and forced out of the front of the chamber.
- 6.1.4. **TEMPERATURE LIMIT CONTROL.** The heater is equipped with a temperature limit control designed to turn the heater off should the internal temperature rise to an unsafe level. If this device activates and turns your heater off, it may require servicing. Once the temperature falls below the reset temperature, you will be able to restart the heater.
- 6.1.5. **ELECTRICAL SYSTEM PROTECTION.** The heater's electrical system is protected by a circuit breaker that protects the systems components from damage. If the heater ceases to work, check the fuse first and replace if necessary. See maintenance section 7.9.
- 6.1.6. **FLAME SENSOR.** The heater uses a photocell to 'see' the flame in the combustion chamber. Should the flame extinguish, the sensor will cut off the electrical current and the heater will shut down.

6.2. TO START THE HEATER

- 6.2.1. Fill the tank with fuel until the fuel gauge points to "F". **DO NOT** overfill.
- 6.2.2. Ensure that the fuel cap is replaced and fully tightened down.
- 6.2.3. Unwind the mains cable from cable ties and plug the heater into the mains power supply.
- 6.2.4. Turn the thermostat control knob to the desired temperature. The range is from 40°F to 110°F. (4.4°C to 43°C)
- 6.2.5. Push the power switch to the ON position.
- 6.2.6. The power lamp will illuminate and the heater will start. The heater will run up to the preset temperature and then switch on and off automatically to maintain the preset temperature.
- 6.2.7. If the heater will not start, the temperature may be set too low. Turn the temperature control knob to a higher setting until the heater fires. If the heater still does not start turn the power switch to OFF, then turn back ON. If the heater still does not fire refer to the troubleshooting guide.

NOTE: The electrical components of these heaters are protected by a fuse mounted on the PC board. If the heater will not fire, check this fuse first and replace if necessary. Also check that the proper voltage is being supplied to the heater.

6.3. TO STOP THE HEATER.

- 6.3.1. Turn the power switch to OFF and disconnect the mains power supply. **NEVER SHUT DOWN THE HEATER BY PULLING OUT THE PLUG. DO NOT** touch the heater outlet as this will remain hot for some time. Store without fuel (see section 7.10.) in a dry, safe, childproof area.
- 6.4.1 Wait ten seconds after shutting off the heater.
- 6.4.2 Turn the power switch to ON.

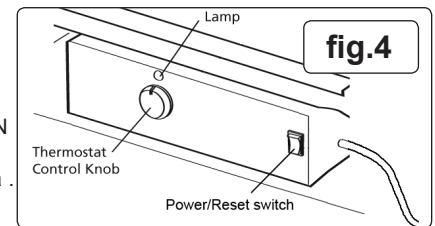

7. MAINTENANCE



WARNING! MAINTENANCE MUST ONLY BE UNDERTAKEN BY A QUALIFIED PERSON. WE STRONGLY RECOMMEND THAT ALL SERVICING IS DONE BY YOUR LOCAL SERVICE AGENT.

7.0. MAINTENANCE SCHEDULE

- ❑ **WARNING! Never attempt to service the heater whilst it is still hot, wait until it has cooled enough to touch. Unplug the heater from the mains supply before servicing.**

Use only genuine Sealey replacement parts. Use of alternative/third party components will cause unsafe operation and will invalidate your warranty.

7.1. FUEL TANK

Clean out the fuel tank every 200 hours of operation or as needed. Flush out with paraffin, kerosene or diesel fuel depending on which fuel you are using. Do not use any other liquid for this operation.

7.2. AIR FILTERS (See fig.5) The *air intake filter* should be replaced or washed with soap and water and thoroughly dried every 500 hours of operation or less, depending on the conditions of operation.

The *air output filter* and *lint filter* should be replaced every 500 hours or more frequently depending on conditions of use.

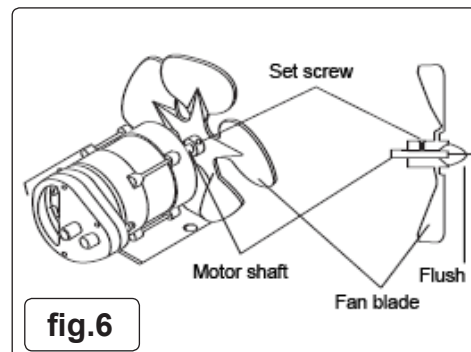
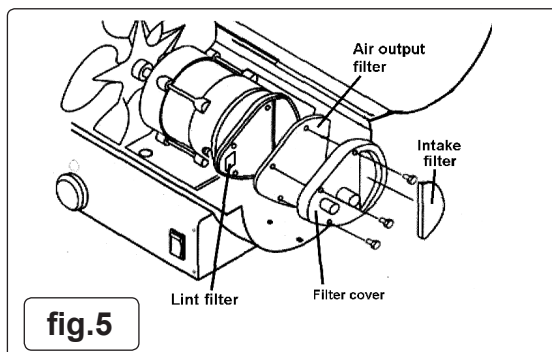

7.3 FAN BLADES (See fig.6)

The fan blades should be cleaned at least once per heating season, depending on conditions in the area of use. Remove all accumulated dust and dirt with a damp cloth, taking care not to bend any of the fan blades. Dry the fan blades thoroughly before restarting the heater. For fan removal see fig.6.

7.4 NOZZLE (See fig.7)

The nozzle should be cleaned at least once per heating season. Use of contaminated fuel will make it necessary to clean the nozzle more frequently. To clean dirt from the nozzle, blow compressed air through the front of the nozzle. It may be necessary to soak the nozzle in paraffin, kerosene first in order to loosen any dirt particles.

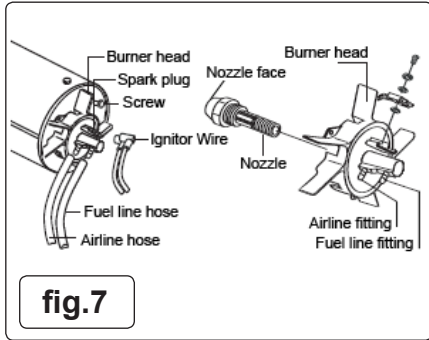

fig.7

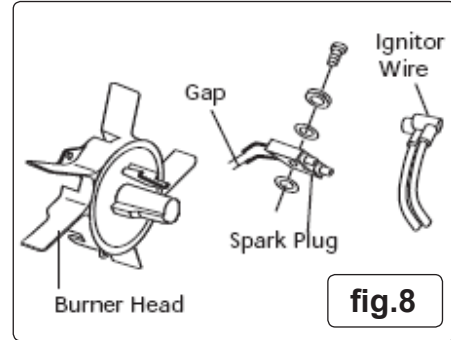

fig.8

7.6. PHOTO CELL (See figs.9&10)

The photocell should be cleaned at least once per heating season or more depending on conditions of use. Use a cotton swab dipped in water or alcohol to clean the lens of the photocell. The positioning of the photocell is critical to its correct operation. See fig.10 for the correct installation.

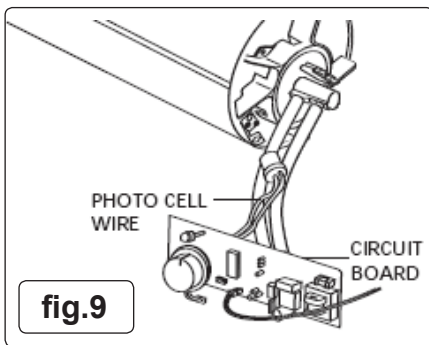

fig.9

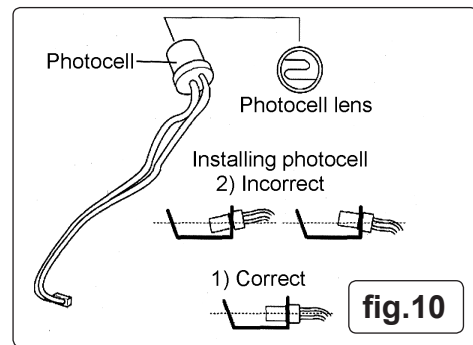

fig.10

7.7. FUEL FILTER (See fig.11)

The fuel filter should be cleaned at least twice per heating season by rinsing it in clean paraffin or kerosene. Use of contaminated fuel will make it necessary to clean the filter more frequently. To remove the filter first squeeze the legs of the fuel line clip and move it up the fuel line. Ease the fuel line from off the filter head. Turn the hexagonal head of the filter 90° anti-clockwise and ease it upwards and out of the tank.

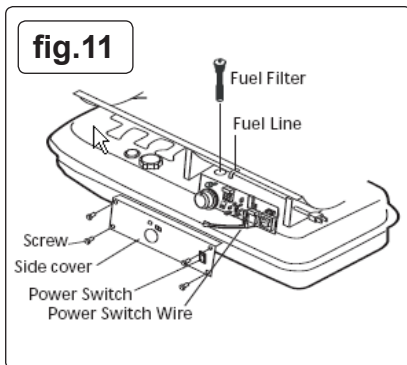

fig.11

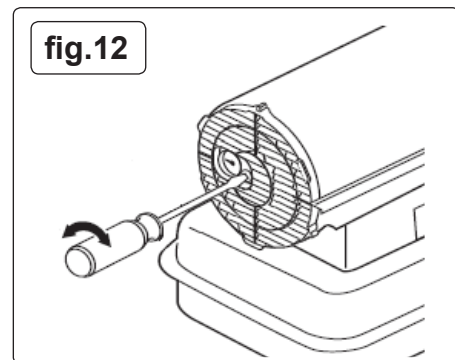

fig.12

7.8. PUMP PRESSURE ADJUSTMENT (See fig.12)

For the efficient burning of fuel and optimum heat output the pump on this heater is designed to run at the specific pressures indicated below.

MODEL No:	PUMP PRESSURE
AB708	3.7PSI ±10%

Periodically check the pump pressure by referring to the pressure gauge within the rear grille. If adjustment is required turn the adjusting screw located to the right of the gauge using a slotted screwdriver as shown in fig.12.

7.9. FUSE REPLACEMENT (See fig.13)

NOTE: This is a fuse protected heater.

If your heater fails to ignite check the fuse as shown in fig.13 before contacting your local service agent.

- ☐ **WARNING:** Unplug the heater from the mains power supply before attempting any maintenance work.
- 7.9.1. Remove the control panel screws using a medium cross point screwdriver and lift off the side panel to reveal the printed circuit board.
- 7.9.2. Disconnect switch wires from the power switch.
- 7.9.3. Remove fuse from holder as shown below.
- 7.9.4. Replace fuse with one of the same specification.

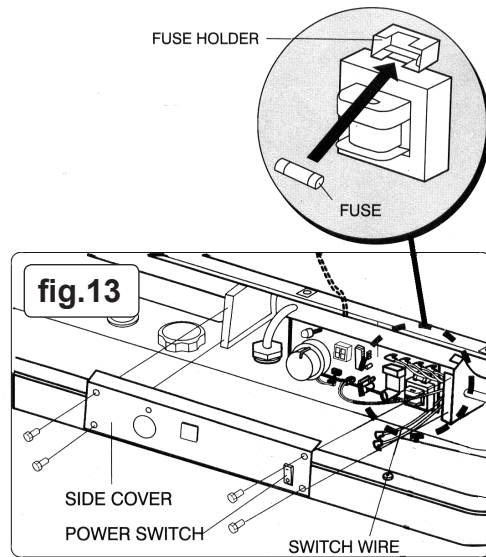

7.10. LONG TERM STORAGE

If the heater is to be stored for a long period of time, drain the fuel through the fuel cap opening. Rinse and swirl a small amount of fuel within the tank and then empty it fully. When you come to use the heater again do not use old fuel which has been stored from the previous season. Use of old fuel can damage your heater.

Although our heaters operate with diesel fuel, when the temperature is below 0°C diesel additives are required to maintain the diesel's viscosity. Typically diesel can cloud in freezing conditions and will start to gel. You will need additives for your fuel in these conditions.

Kerosene/Paraffin does not start to gel until the ambient temperature is around -40°C.

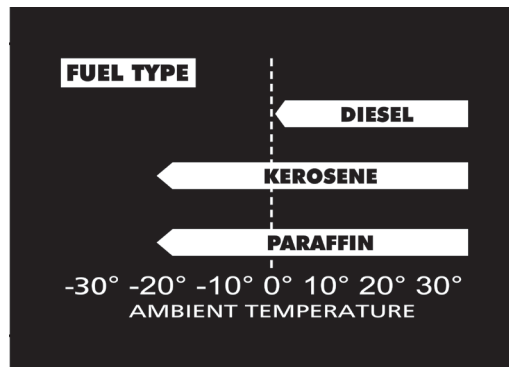

ENVIRONMENT PROTECTION



Recycle unwanted materials instead of disposing of them as waste. All tools, accessories and packaging should be sorted, taken to a recycling centre and disposed of in a manner which is compatible with the environment. When the product becomes completely unserviceable and requires disposal, drain any fluids (if applicable) into approved containers and dispose of the product and fluids according to local regulations.

WEEE REGULATIONS



Dispose of this product at the end of its working life in compliance with the EU Directive on Waste Electrical and Electronic Equipment (WEEE). When the product is no longer required, it must be disposed of in an environmentally protective way. Contact your local solid waste authority for recycling information.

Note: It is our policy to continually improve products and as such we reserve the right to alter data, specifications and component parts without prior notice.

Important: No Liability is accepted for incorrect use of this product.

Warranty: Guarantee is 12 months from purchase date, proof of which is required for any claim.

Sealey Group, Kempson Way, Suffolk Business Park, Bury St Edmunds, Suffolk. IP32 7AR



01284 757500



01284 703534



sales@sealey.co.uk



www.sealey.co.uk